

Forged Machinery Eye Bolts

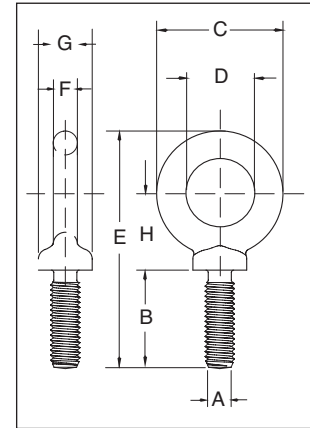

S-279 / M-279
Shoulder Type
Machinery Eye Bolts

- Forged Steel - Quenched & Tempered.
- Working Load Limits shown are for in-line pull. For angle loading, see page 202.
- Fatigue rated at 1-1/2 times the Working Load Limit at 20,000 cycles. traceability, not addressed by ASME B30.26.
- Recommended for in-line pull.
- S-279 threaded UNC.
- M-279 metric threaded.
- Meets or exceeds all requirements of ASME B30.26 including identification, ductility, design factor, proof load and temperature requirements. Importantly, these bolts meet other critical performance requirements including fatigue life, impact properties and material



S-279 UNC Shoulder Type Machinery Eye Bolts

Size (mm)	S-279 Stock No.	Working Load Limit (t)*	Weight Each (kg)	Dimensions (mm)							
				A** Thread	B	C	D	E	F	G	H
6.35 x 25.4	9900182	.29	.02	1/4 - 20	25.9	28.7	19.1	58.0	4.85	13.5	19.6
7.94 x 28.6	9900191	.54	.04	5/16 - 18	29.2	35.1	22.4	69.5	6.35	15.0	24.1
9.53 x 31.8	9900208	.70	.06	3/8 - 16	32.3	41.1	25.4	78.0	7.85	17.5	26.7
12.7 x 38.1	9900217	1.18	.12	1/2 - 13	38.9	49.5	30.2	94.0	9.65	23.1	32.3
15.9 x 44.5	9900226	2.35	.24	5/8 - 11	45.5	60.5	35.1	113	12.7	28.7	38.9
19.1 x 51.0	9900235	3.26	.43	3/4 - 10	52.0	70.0	38.1	129	16.0	35.1	43.4
22.2 x 57.0	9900244	4.80	.70	7/8 - 9	58.5	82.5	44.5	149	19.1	39.6	50.8
25.4 x 63.5	9900253	6.03	1.1	1 - 8	65.5	95.5	51.0	169	22.4	46.0	58.4
28.5 x 70.0	9900257	6.80	1.5	1-1/8 - 7	69.8	107	57.1	183	24.6	52.3	59.7
31.8 x 76.0	9900262	9.52	1.8	1-1/4 - 7	78.5	114	63.5	202	25.4	58.0	69.3
38.1 x 89.0	9900271	10.8	3.2	1-1/2 - 6	91.5	140	76.0	241	31.8	70.0	83.3
44.5 x 95.0	9900280	15.4	4.7	1-3/4 - 5	95.2	159	88.9	266	35.0	76.2	91.4
51 x 102	9900289	19.0	8.6	2 - 4-1/2	102	194	101	313	46.0	85.9	114
63.5 x 127	9900298	29.5	14.5	2-1/2 - 4	127	223	114	378	53.8	108	140

*Ultimate Load is 5 times the Working Load Limit. Maximum Proof Load is 2 times the Working Load Limit. ** All bolts threaded UNC.



M-279 Metric

Size (mm)	M-279 Stock No.	Working Load Limit (t)*	Weight Each (kg.)	Dimensions (mm)							
				A** Thread	B	C	D	E	F	G	H
M6 x 13	1045753	.20	.03	M6 x 1.0	13.0	28.7	19.1	47.0	4.9	13.5	19.6
M8 x 13	1045789	.40	.05	M8 x 1.25	13.0	35.1	22.4	54.6	6.4	15.0	24.1
M10 x 17	1045833	.64	.07	M10 x 1.5	17.0	41.1	25.4	64.3	7.9	17.5	26.5
M12 x 20.5	1045869	1.0	.11	M12 x 1.75	20.5	49.5	30.2	77.7	9.7	23.1	32.8
M16 x 27	1045913	1.8	.25	M16 x 2.0	27.0	60.5	35.1	96.0	12.7	28.7	38.9
M20 x 30	1045995	2.5	.42	M20 x 2.5	30.0	70.0	38.1	108	16.0	35.1	43.4
M24 x 36	1046029	4.0	1.05	M24 x 3.0	36.0	95.5	51.0	142	22.4	46.0	58.4
M27 x 69.8	1046038	5.0	1.42	M27 x 3.0	69.8	107	57.1	183	24.6	52.3	59.7
M30 x 45	1046075	6.0	1.77	M30 x 3.5	45.0	114	63.5	171	25.4	58.0	69.3
M36 x 54	1046109	8.5	3.12	M36 x 4.0	54.0	140	76.0	207	31.8	70.0	83.3
M42 x 95.2	1046118	14.0	4.58	M42 x 4.5	95.2	159	88.9	266	35.0	76.2	91.4
M48 x 102	1046127	17.3	8.71	M48 x 5.0	102	194	101	313	46.0	85.9	114
M64 x 127	1046136	29.5	14.74	M64 x 6.0	127	223	114	378	53.8	108	140

*Ultimate Load is 5 times the Working Load Limit. Maximum Proof Load is 2 times the Working Load Limit. ** On Request: Special threading or as forged bolts for customer conversion.